

OWYHEE COUNTY COMMUNITY PLANNING

P.O. Box 128
17069 Basey Street
Murphy, ID 83650

Phone: (208) 495-2095
Fax: (208) 495-2051
www.owyheecounty.net

Dear Applicant:

To assist you in filing your conditional use permit application, the following items are enclosed:

1. Detailed Instructions
2. Table of Contents/Checklist (Note that each section must be tabbed & compiled in the order of the included table of contents)
3. Application Form
4. Affidavit
5. Fee Schedule
6. Hearing Procedures
7. Contact List
8. Right to Farm Disclosure Statement
9. Standard Special Conditions

Prior to completing this packet, please schedule a pre-application meeting with planning staff to discuss the conditional use permit process. Once you have completed your packet, please schedule a follow up meeting with staff to review your completed application packet. We are happy to assist you with any questions you have while compiling your packet. If your application is found to be incomplete, it will not be accepted. Applications are not considered filed until they are accepted and signed by staff as complete. No hearing will be scheduled until the application is signed by staff as complete and all fees are paid.

The Owyhee County Code and the Comprehensive Plan are available to download on the County Web site under the "Codes and Plans" tab. Please read Chapter six (6) of the Zoning Ordinance carefully, as it sets out your responsibility when applying for a conditional use permit. To summarize:

By the requesting of a Conditional Use Permit, you are asking that you be excused from the law as it pertains to your land use situation. This is not a request that is taken lightly. The Applicant has the burden of proof; this means that you must supply sufficient evidence which will justify the granting of the permit as it relates to the Comprehensive Plan and the Owyhee County Code.

The following questions must be addressed by you, with substantial supporting evidence. The following criteria are the standards used by the Commission to decide whether or not a conditional use permit will be approved. A one sentence answer will not be sufficient.

1. Whether the intended use is necessary or desirable to the public convenience and welfare.
2. Whether the proposed use may create a hazard, nuisance, detriment or other injury to other property in the immediate vicinity or to the health or safety to the citizens of the county in general.
3. Whether essential public services, or the general public health or safety, or the general public environment may be negatively impacted by such use or whether there may be a requirement of additional public funding in order to meet the needs created by the requested use.
4. Whether adequate sewer, water and drainage facilities, and utility and other service systems are to be provided by the applicant to accommodate said use.
5. Whether the proposed use may have adverse impact on water supplies, both surface and underground.
6. Whether the geological base on which the use is to be placed may or may not support the proposed use.
7. Whether the proposed use at the site may endanger human health, animal life and plant life in the surrounding area and/or the county in general. (i.e. species of animals or plants, or their habitats which might be harmed or interfered with by the proposed use.)
8. Whether the proposed use compliments, benefits, and is compatible with the surrounding land uses.
9. Whether special conditions could be imposed upon the proposed use which would so minimize any adverse impact as to justify the granting of the conditional use permit. In responding to this point, please consider and propose any special conditions which the commission could issue which would minimize or mitigate any adverse impact as described in all of the above questions.

Every approved conditional use permit will have standard special conditions imposed; a copy of those conditions is attached as part of this application packet. Be advised that when special conditions are imposed on a conditional use permit approval, any violation of the special conditions will be deemed a violation of the County Code.

If you have questions about what type of information to provide, please refer to the detailed instruction page. If your question is still not answered, please contact our office at (208) 495-2095, ext. 2 or email mhuff@co.owyhee.id.us.

Thank you,

Owyhee County Community Planning

INSTRUCTIONS TO PROVIDING A COMPLETE APPLICATION

Incomplete submissions will be returned. No hearing will be scheduled until applications are certified as complete by staff and all fees paid.

**One complete original file and six identical copies must be submitted to our office.
(Remember to prepare a copy for yourself to be used in your hearing presentation)**

Submitted application must be compiled in order of the provided table of contents. Additionally, each main heading page must be tabbed and indexed according to table of contents for ease of presentation.

Detailed letter to the Commission addressing the following:

- A detailed description of your request. Summarize your project.
- Exactly how and where the parcel is legally accessed.
- If the access will require crossing over private property other than your own, a recorded easement to the subject parcel must be provided in your application packet.
- Whether or not the subject parcel is in a herd district. (If you are in a herd district, livestock must be fenced in by the owner. If you are not in a herd district, it is each individual's responsibility to fence out livestock.)
- A description of the surrounding land uses of all property bordering the subject parcel in all directions, north, east, south, and west.
- Describe source of domestic water and ownership (example: private well, shared well and with whom, community water system).
- If there is irrigation water allocated to the property, provide information concerning the number of water shares, how water is delivered, description of the point(s) of diversion, and any other information relevant to irrigation that your proposed use may impact.

Review Criteria

On a separate page, or pages, please give your well thought out answers to the below 9 review criteria. Each question is to be presented in your application packet with the review criteria being stated first and your answer providing sufficient facts and evidence to follow. Please do not just restate the review criteria with a yes or no preceding it. This is your opportunity to try to prove to the Commission why granting you a conditional use permit is desirable to Owyhee County, the area surrounding your parcel, and its neighboring land owners.

1. Whether the intended use is necessary or desirable to the public convenience and welfare.
2. Whether the proposed use may create a hazard, nuisance, detriment or other injury to other property in the immediate vicinity or to the health or safety to the citizens of the county in general.
3. Whether essential public services, or the general public health or safety, or the general public environment may be negatively impacted by such use or whether there may be a requirement of additional public funding in order to meet the needs created by the requested use.

4. Whether adequate sewer, water and drainage facilities, and utility and other service systems are to be provided by the applicant to accommodate said use.
5. Whether the proposed use may have adverse impact on water supplies, both surface and underground.
6. Whether the geological base on which the use is to be placed may or may not support the proposed use.
7. Whether the proposed use at the site may endanger human health, animal life and plant life in the surrounding area and/or the county in general. (i.e. species of animals or plants, or their habitats which might be harmed or interfered with by the proposed use.)
8. Whether the proposed use compliments, benefits, and is compatible with the surrounding land uses.
9. Whether special conditions could be imposed upon the proposed use which would so minimize any adverse impact as to justify the granting of the conditional use permit. In responding to this point, please consider and propose any special conditions which the commission could issue which would minimize or mitigate any adverse impact as escribed in all of the above questions.

Deeds

A copy of the current recorded deed must also be provided along with the legal description of the property. If requesting to divide the parcel, a map showing how the parcel appeared on August 13th, 1979 is required along with the corresponding deed.

If you do not have access to these documents, you can research this information at the County Courthouse or some title companies will perform a deed search for you. The purpose of this research is to prove that the original (pre 1979) parcel has not been divided into more than four pieces. If it has, your proposed use will be subject to the Owyhee County Subdivision requirements.

Maps

(PLEASE HIGHLIGHT YOUR LOCATION AND IDENTIFY NORTH ON ALL MAPS)

Detailed site plan must show: (see attached example)

- Minimum size of paper for site plan shall be 8 ½” x 11”
- North should be up on your map indicated by a directional arrow at the top of the page.
- The size, shape and dimensions of the subject property
- The location of existing structures with their uses indicated: Residence, outbuildings, etc....
- Placement of proposed structures or outlined construction zone to be no larger than one acre.
- Nearest Public roads, show existing and proposed accesses.
- Width and length of proposed roads.
- Power lines, phone lines, and water lines.
- Type and width of any easements.



Owyhee County Conditional Use Permit Site Plan Example

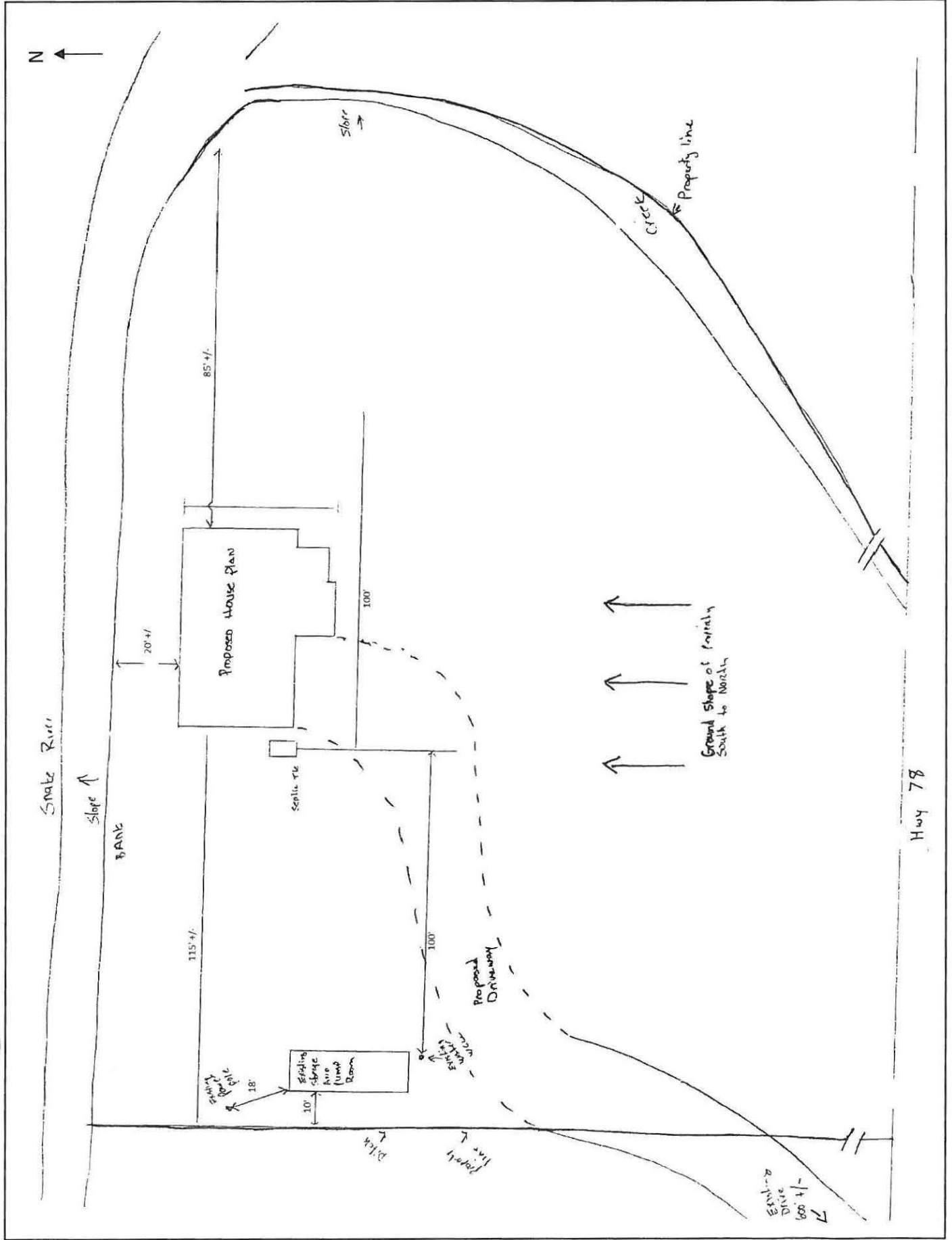

Irrigation Map

- Irrigation infrastructure, point of diversion, and any other relevant irrigation information.
- The location of any distinguishing physical features located on or adjacent to the property such as streams, ponds, culverts, drainages, wetlands, slopes, ditches or canals.
- Indicate direction of ground slope and water flow.

Vicinity Map

The vicinity map should show your location in relation to the surrounding area. A road map within an approximately one-mile radius would be sufficient. Please identify your location on the map with a highlighted box around it. This map should allow anyone to be able to find your location by reading the map. You can get this sort of map from the internet at websites like www.google.com or www.mapquest.com

Parcel Map

You can get this map from the county parcel map on the county web site www.owyheecounty.net . If requesting to divide the parcel, this map must have the original parcel outlined and highlighted showing how existed as of August 1, 1979. Your proposed parcel must also be clearly identified by highlighter, and any proposed divisions must be drawn in with dotted lines. (Deeds provided must include the legal description that matches the outlined parcel from 1979 or the most recent deed prior to that date. This will show how many times the parcel has been divided since 1979)

Two Color Aerial Maps

Your aerial maps must be in color. The first should show an approximately one-mile radius from your proposed site. Please identify and outline your proposed location with a highlighter or marker. This type of a map can be obtained from various internet sources such as Google Earth. This map should show the land bordering your subject parcel on all sides. The second aerial map should be zoomed in close enough to show site details of the subject parcel.

Zone Map

You can get this map from the Planning office. Show your subject parcel by highlighting your location on the zone map.

Soil Classification

This must be the soil classification as determined by U.S. NRCS. This report will show a map with land contours and soil classifications within each of the outlined areas of the soil classification land map. The first page of this report will be an overview of the parcel with the contours and the following pages will list the soil types found on your parcel and details about their classifications. This information can also be obtained from their web site at websoilsurvey.nrcs.usda.gov

Correspondence - (See contact list for names, addresses, and phone numbers)

Contact local taxing Districts to inform them of your proposal and request comments from their office. A copy of your letter to each district must be included with your application packet. Your letter should include a description of your proposed project, the location of the subject parcel, and a simple map showing the area. By contacting these agencies, it gives you the opportunity to address any of their concerns prior to your public hearing. Planning staff will mail a notification of your hearing date and time to each of these agencies prior to your public hearing. Your letter to the road district should specifically address the location of all proposed or existing access points adjoining roads they have jurisdiction over. Your letter to the irrigation district should include a copy of your irrigation map. A response from each agency will help you meet the burden of proof as to no adverse impact on the Agency. We encourage you to make every attempt to get a response. Sending letters by registered mail is not required, but proves you made an attempt to solicit their input. If you do not receive comments from them, be prepared to prove to the commission that there will be no adverse impact caused by your requested use.

TABLE OF CONTENTS

General

Application.....
Affidavit (this only needs to be filled out if you do not own the property).....
Detailed Letter Describing the Request
Review Criteria 1- 9.....

Legal Documents

Copy of current deed or quit claim deed.....
Legal Description

Maps (highlight your location and identify North on all maps)

Detailed Site Plan with all proposed structures
Vicinity Map
Assessor Parcel Map
Aerial Map
Zone Map

Environmental

Soil Classification

Correspondence – Letter to agency and their response back

Applicant Letter requesting comments
Fire District
Irrigation District
Road District
School District

Appendix A – (If needed)

Right to Farm
Additional Information Pertinent to Application.....

**Owyhee County
Planning & Zoning**

**PO Box 128, Murphy, ID 83650
Phone (208) 495-2095 Fax (208) 495-2051**

**Land Use Permit Application
Requiring Public Hearing**

- SINGLE FAMILY RESIDENCE COMMERCIAL SUBDIVISION CAFO INDUSTRIAL
 REZONE OTHER _____

APPLICANT/ APPLICANT REPRESENTATIVE

PROJECT ADDRESS/LOCATION

MAILING ADDRESS

SECTION TOWNSHIP RANGE

CITY STATE ZIP CODE

Does this parcel border dry land/range land? Y N
(If yes, please include fire mitigation measures on site plan)

TELEPHONE EMAIL OR FAX

TAX ASSESSOR'S PARCEL NUMBER(S)

OWNER'S NAME

CURRENT ZONING OF THE SUBJECT PARCEL

OWNER'S MAILING ADDRESS

CURRENT USE OF THE SUBJECT PARCEL

CITY STATE ZIP CODE

PROPOSED USE

OWNER'S PHONE NUMBER EMAIL OR FAX

TOTAL SQ. FT OF ALL PROPOSED STRUCTURES

I DECLARE UNDER PENALTY OF PERJURY that I/we, _____, being duly sworn, depose and say that I/we am/are the applicant(s) in the foregoing application, that I/we have read the foregoing application and know the content thereof and state that the same is true and correct to the best of my knowledge. Furthermore, all information and data submitted to Owyhee County in support of my application is true and correct to the best of my knowledge. I/we acknowledge that by submitting this application a member or members of the planning and zoning commission may physically make a site visit to the proposed site and surrounding vicinity. I/we understand that this will be done at an unannounced time without conversation with owners, applicants, or the public.

Dated: _____ Signed: _____

Dated: _____ Signed: _____

On the ____ day of _____, _____, before me, the undersigned Notary Public, personally appeared, known to me to be the person(s) whose name(s) is/are subscribed to the foregoing instrument, and acknowledged to me that s/he executed the same.

IN WITNESS WHEREOF, I have set my hand and seal the day and year as above written.

Notary Public

Residing at _____
Commission Expires: _____

FOR ADMINISTRATIVE USE
File No. _____ Rec'd by: _____ Date: _____ Pd. _____ Check No. _____

AFFIDAVIT

STATE OF IDAHO)
COUNTY OF OWYHEE)

I, _____, being duly sworn, depose and say that I am the applicant in the foregoing application, that I have read the foregoing application and know the content thereof and state that the same is true and correct to the best of my knowledge. Furthermore, all information and data submitted to Owyhee County in support of my application is true and correct to the best of my knowledge.

APPLICANT SIGNATURE

ADDRESS

CITY/STATE/ZIP

TELEPHONE

I, _____, the owner (if other than the applicant) of the real property involved in this application, do hereby consent to the filing of this application.

OWNER SIGNATURE

ADDRESS

CITY/STATE/ZIP

TELEPHONE

On the _____ day of _____, _____, before me, the undersigned Notary Public, personally appeared _____, known to me to be the person(s) whose name(s) is/are subscribed to the foregoing instrument, and acknowledged to me that s/he executed the same.

IN WITNESS WHEREOF, I have set my hand and seal the day and year as above written.

Notary Public

Residing at _____
Commission Expires: _____

Fee Schedule

All Fees include payment for an application, processing, and a decision.

Fees do not include the following, when required, which the applicant will be required to pay after costs are determined:

- 1) Bonding required improvements,
- 2) Recording any documents at the Recorder's Office, and
- 3) Actual expenses for facility rental and/or County-contracted engineering (plat/plan review, improvement inspections, etc.)
- 4) Any studies deemed necessary by the Planning & Zoning Commission

ZONING	FEE	
Property Research Information	\$100.00	Per parcel
Silver City Application review	\$100.00	
Certificate of Zoning Compliance	\$25.00	
Floodplain Development	\$70.00	
Simple Changes to Recorded Plat	\$245.00	
Administrative Discretion Decision	\$200.00	
Time and Materials	Actual cost	
Variance	\$1,000.00	
PLANNING	FEE	
Comprehensive Plan Change	\$2,008.00	
Conditional Use Permit		
Seeking Single Family Residence	\$1,200.00	
Seeking a second dwelling on a parcel	\$1,200.00	
Seeking two new dwellings on a parcel	\$1,500.00	
Seeking temporary anemometer tower	\$379.00	
Seeking Commercial/Industrial Use	\$4,000.00	
Seeking Gravel Pit	\$4,500.00	
Seeking Dairy or Feedlot Use (up to 5,000 head)	\$5,500.00	Additional \$100 per 1,000 head over 5,000
Solar Net-Metering Systems (non-commercial)	\$1,200.00	\$1,200 for 10-75 kW ground mounted systems & 25-75 kW roof mounted systems. \$1,500 for non-commercial systems over 75 kW
Other Uses	\$3,000.00	
Modification of special condition	\$1,000.00	
Time Extensions	\$1,000.00	
Minor Subdivision (up to 10 lots)	\$1,300.00	\$1,300 for first lot - \$300.00 for each additional lot (up to 10 lots total)
Major Subdivision (Over 10 lots)	\$4,000.00	\$4,000 for first 10 lots - Additional \$25.00 per lot over 10
Major Industrial		Negotiated on case-by-case basis
Conditional Use Permit Vacation Request	\$350.00	
Conditional Rezone	\$5,000.00	
Development Agreement Administrative Review	\$2,500.00	
Decision		
Any Decision to BOCC (appeal, change road name, amend Board condition, etc.)	\$3,000.00	
Remand Hearing Fee	\$600.00	
Motion to Reconsider Decision	\$600.00	
Ordinance Amendment	\$4,000.00	
Planned Unit Development		Negotiated on a case-by-case basis
Rezone with/without Comprehensive Plan Map Change	\$1,500.00 *	
Subdivision		
Preliminary Plat	\$980.00	
Final Plat	\$700.00	
Short Plat	\$1,680.00	
Grading Plan (Includes Preliminary and Final Plan)	\$140.00	
Vacate a plat, lot, road, easement, etc.	\$805.00	
Irrigation Plan	\$70.00	
Waivers	\$70.00	
Mediation (Payment for Notification only) 07-05-07		
By Resolution on a case by case basis		
Refund Policy for Applications that are Withdrawn:		
An applicant may request a refund of 90% of the application fee within 7 calendar days of the application, after which time no refund may be granted.		
Note: Fees are cumulative.		

HEARING NOTICE PLEASE TAKE NOTE:

This is an evidentiary hearing before the Owyhee County Planning and Zoning Commission. It is not a town meeting where anyone in the audience just stands up to talk. Each individual wishing to speak will need to sign in and will be given the opportunity to testify when they are called upon.

This will be a ‘quasi-judicial’ hearing, conducted for the purpose of hearing evidence in the form of testimony under oath and/or offering exhibits relevant to the application.

Because of the nature of the hearing being quasi-judicial, it is not appropriate for a proponent or opponent to contact any member of the Planning and Zoning Commission to discuss a pending application. If you have questions, please direct them to the Planning and Zoning office at 208-495-2095 ext. 2.

Petitions containing some sort of statement with signatures may or may not be relevant. This is not a voting contest, it is a hearing authorized by the Idaho Code and the Owyhee County Code (Zoning Ordinance).

Hearing procedures are posted in the hearing room at least 30 minutes prior to the start of the hearing. Additionally, general procedures will be announced prior to the commencement of the hearing. Persons who qualify to testify will be called upon to speak under oath. The applicant and any witnesses of the applicant will testify first, then anybody who signs in wishing to testify as neutral, and finally, any opposition will testify last followed by a rebuttal by the applicant.

It is possible that a time limit will be imposed on speakers sworn to testify. If this is a concern, please call ahead of time to find out if time limits will be imposed.

It is important that members of the audience remain quiet during the proceedings and that only one person speak at a time so that the recording of the hearing will remain clear for transcription as required by law. Please make sure that all cell phones are turned off during the hearing. If you need to make a phone call, please step outside to do so.

Any person needing special accommodations to participate in a public hearing should contact The Planning and Zoning Department at least seven (7) days prior to the meeting at Owyhee County Annex Building, PO Box 128, Murphy, Idaho 83650, or by calling 208-495-2095 est. 2.

Contact List

County

Owyhee County
Planning and Zoning
PO Box 128
Murphy, ID 83650
208-495-2095 ext. 2
Fax 208-495-2051

Owyhee County Sherriff
PO Box 128
Murphy, ID 83650
208-495-1154

Owyhee County Assessor
PO Box 128
Murphy, ID 83650
208-495-2817

Civil Dynamics
305 Cornell St.
Middleton, ID 83644
208-453-2028

Owyhee Cattlemen's Association
PO Box 400
Marsing, ID 83639
208-896-4104
Fax 208-896-4105

Bruneau

Bruneau Fire District
PO Box 243
Bruneau, ID 83604
Stacey Buckingham 208-845-2288

Bruneau Water & Sewer District
PO Box 181
Bruneau, ID 83604
208-845-2288

Owyhee County Road & Bridge
District #3
C/O Travis Jewett
PO Box 573
Grand View, ID 83624
208-834-2012

Bruneau/Grand View
School Dist. #365
39678 State Highway 78
Bruneau, ID 83604
208-834-2260

Little Valley Mutual Irrigation Company
PO Box 160
Grand View, ID 83624
Preston Koehn 208-845-2574

Hot Springs Ditch Co.
C/O Chris Alzola
PO Box 235
Mountain Home, ID 83647
Chris Alzola 208-587-2789

South Side Bruneau Canal Co.
C/O Chris Alzola
PO Box 235
Mountain Home, ID 83647
Chris Alzola 208-587-2789

Bruneau Buckaroo Co-op Ditch Co.
C/O Chris Alzola
PO Box 235
Mountain Home, ID 83647
Chris Alzola 208-587-2789

Grand View

Bruneau/Grand View
School Dist. #365
39678 State Highway 78
Bruneau, ID 83604
208-834-2260

Grand View Fire District
PO Box 54
Grand View, ID 83624
Greg Becker 208-590-2828

Grand View Irrigation District
PO Box 9
Grand View, ID 83624
Dixie McDaniel 208-834-2350

City of Grand View
PO Box 69
Grand View, ID 83624
208-834-2700

Contact List

Castle Creek Water District 57C
Watermaster Michael B Ihli
625 S School Ave
Kuna, ID 83634
208-867-5736
mikeihli@gmail.com

Murphy

Owyhee County Road & Bridge
District #1
PO Box 128
Murphy, ID 83650
Phil Rittenhouse
208-495-1170

Murphy/Reynolds/Wilson
Fire District
11606 State Hwy 78
Melba, ID 83641
208-404-9746 Chuck Cooley
chief@mrwfire.org

Melba Quick Response Unit
PO Box 33
Melba, ID 83641
208-495-1211

Melba School District
Superintendent
511 Broadway Ave.
PO Box 185
Melba, ID 83641
208-495-1141

Reynolds Irrigation District
PO Box 12
Melba, ID 83641
Brad Huff 208-495-2950

West Reynolds Irrigation District
15859 State Hwy. 78
Melba, ID 83641
Adam Duckett 208-409-8524

Catherine Creek Water District 57B
18125 Oreana Loop Rd
Oreana, ID 83650
Rohl Hipwell 208-834-2431

Sinker Creek Water District 57D
23202 Dust Devil Ln
Murphy, ID 83650
Chad Nettleton 208-850-0780

Reynolds Creek Water District 57R
9902 Wilson Cemetery Lane
Wilson, ID 83641
Connie Brandau 208-495-2529

Marsing

Gem Highway District
PO Box 453
Marsing, ID 83639
Keith Berends - Road Supr.
Shop 208-896-4581
gemhighwaydistrict@gmail.com

Marsing Fire Dept.
PO Box 299
Marsing, ID 83639
Jerry Mayer 208-550-6010
marsingfiredistrict@yahoo.com

Marsing School District
Superintendent
PO Box 340
Marsing, ID 83639
208-649-5411

Opaline Irrigation District
PO Box 331
Marsing, ID 83639
208-880-9695 Pam Howard
opalineirrigationdistrict@hotmail.com

City of Marsing
PO Box 125
Marsing, ID 83639
208-896-4122

Homedale

Gem Irrigation District
South Board of Control
PO Box 67
Homedale, ID 83628
208-337-3505
office@southboardofcontrol.com

Contact List

Homedale Fire Protection District
PO Box 905
Homedale, ID 83628
Dennis Uria 208-880-4194

Homedale School District
Superintendent
116 E. Owyhee Ave
Homedale, ID 83628
208-337-4611

Homedale Highway District
PO Box 713
Homedale, ID 83628
208-337-3500
hhddaniel@gmail.com

City of Homedale
PO Box 757
Homedale, ID 83628
208-337-4641

Three Creek

Three Creek Road District
56562 Blossom Rd
Rogerson, ID 83302
208-857-2284 Shop
208-727-7137 Dale Sluder
dhsluder@yahoo.com

Three Creek School District
49909 Three Creek Highway
Rogerson, ID 83302
208-857-2281

Water District 47C
Watermaster Raymond Ruffing
3647 N 1200 E
Buhl, ID 83316
208-731-1312

Idaho Agricultural Aviation Association, Inc.
C/O Katie Bane
PO Box 176
Midvale, ID 83645
idahoooo@gmail.com / 208-863-0688

BLM

Owyhee Field Office
20 First Ave W
Marsing, ID 83639
Donn Christiansen 208-896-5912

Bureau of Land Management
3948 Development Ave.
Boise, ID 83705
208-384-3300

Boise District BLM
District Manager
3948 Development Ave
Boise, ID 83705
208-384-3391

State Offices

Idaho Dept. of Water Resources
Western Regional Office
2735 Airport Way
Boise, ID 83705
208-334-2190
westerninfo@idwr.idaho.gov

Idaho Transportation Dept.
8150 Chinden Boulevard (physical address)
PO Box 8028
Boise, ID 83707
208-334-8300 ext. 2
208-332-7190 Ken Couch
ITDD3Permits@itd.idaho.gov
208-334-8338 Sarah Arjona
D3Development.Services@itd.idaho.gov

Southwest District Health
13307 Miami Lane
Caldwell, ID 83607
208-455-5400
Mitch.Kiester@phd3.idaho.gov

Idaho Dept. of Lands
Southwest Supervisory Area
Bob Pietras
8355 W State St
Boise, ID 83714
208-334-3488
Fax 208-853-6372

Contact List

Idaho Dept. of Fish & Game
Southwest Regional Office
15950 N Gate Blvd.
Nampa, ID 83687
208-465-8465
Fax 208-465-8467

Idaho State Dept. of Agriculture
PO Box 7249
Boise, ID 83707
208-332-8550
Fax 208-334-4062

Idaho Transportation Dept.
Aeronautics Division
3483 Rickenbacker St.
Boise, ID 83705
208-334-8775
Fax 334-8789

Idaho DEQ
Boise Regional Office
1445 N Orchard St.
Boise, ID 83706
208-373-0550
Fax 208-373-0287

Federal Offices

EPA
Idaho Operations Office
950 W Bannock
Suite 900
Boise, ID 83702
208-378-5746

United States Dept. of the Interior
Fish & Wildlife Services
1387 S Vinnell Way, Suite 368
Boise, ID 83709
208-378-5243

Sho-Pai Tribe - Ted Howard
PO Box 219
Owyhee, NV 89832
council@shopai.org
208-759-3100

Military

Mountain Home Air Force Base
1050 Desert St.
Building 2215, Suite 159
Mountain Home AFB, Idaho 83648
Byron Schmidt
208-828-4722

Gowen Field
Idaho Military Division Headquarters
4040 W. Guard Street
Bldg. 600
Boise, ID 83705
208-801-4200

Boise Flight Standards Office / FAA
3295 Elder St. Suite 350
Boise, ID 83705
208-387-4000
Fax 208-387-4020

Idaho Army National Guard
Army Aviation Support Facility
3448 W Harvard St. Bldg. 559
Boise, ID 83705
208-272-3976

Army Corps of Engineers
Regulatory Division
720 Park Blvd. Suite 245
Boise, ID 83712
208-433-4464



Owyhee County, Idaho

RIGHT TO FARM Disclosure Statement

- A. It is the intent of the Legislature of the State of Idaho pursuant to IDAHO CODE Title 22 Chapter 45, RIGHT TO FARM ACT to reduce the loss to the state of its agricultural resources by limiting the circumstances under which agricultural operations may be deemed to be a nuisance.
- B. It is the intent of the Owyhee County Board of Commissioners and the Planning and Zoning Commission to uphold, support, and enforce the RIGHT TO FARM ACT.
- C. The County of Owyhee fully supports and permits "agricultural operations" as defined in IDAHO CODE 22-4502, Definitions, when operated in accordance with generally recognized agricultural practices which includes conformity with Federal, State, and local laws and regulations and when not adversely affecting public health and safety.

I acknowledge Idaho's RIGHT TO FARM, and I accept the agricultural environment they protect and do agree to live within said environment.

Name: _____

Name: _____

Address: _____

Legal: Section: _____ Township: _____ Range: _____

Assessor's Parcel Number: _____

Signature _____ Date _____

Signature _____ Date _____

STATE OF IDAHO, County of Owyhee ss.

On this _____ day of _____, 20____, before me, the undersigned, a Notary Public in and for said State, personally appeared:

Known or identified to me to be the person(s) whose name(s) is/are subscribed to the within instrument and acknowledged to me that he/she/they executed the same.

Signature: _____

Name: _____

Residing at: _____

My Commission expires: _____

STANDARD SPECIAL CONDITIONS

- a. Access to the new use must be constructed with an all weather driving surface at least twenty (20) feet wide with a six (6) inch gravel base, graded and compacted, and a turnaround space provided pursuant to the 2012 International Fire Code (Attachment A). Written approval of the access from the local fire district must be provided prior to the issuance of a building permit. If subject property is not within the boundaries of a fire district, the access shall be constructed as previously stated, and approved by the Building Official prior to the issuance of a building permit.
- b. Applicants must recognize, and any future occupant or purchaser of subject parcel must be advised, through recorded marketing disclosure and /or deed restrictions, that any agricultural activity, which is in existence on lands adjoining or in the vicinity of the subject property, may not be considered a nuisance pursuant to the Idaho Right to Farm Act. A signed and recorded Right to Farm affidavit must be provided to the Administrator prior to the issuance of a Certificate of Occupancy.
- c. Approval by Southwest District Health of the septic system and well site must be submitted prior to the issuance of a certificate of occupancy for the new use.
- d. This decision will be recorded by the Administrator prior to the issuance of a certificate of compliance, recording fee having been included in the application fee.
- e. The Applicant must comply with all applicable laws and regulations.
- f. All structures, improvements, and construction must be developed according to the presentation given under oath at the public hearing for which the conditional use permit was approved.
- g. Any new exterior lighting must be shielded. The bulb shall not be visible below a horizontal plane running through the lowest point of the fixture, and no light shall be emitted from the sides of the fixture.
- h. Abandoned and/or junk vehicles, debris, rubbish, or other solid waste will not be allowed to accumulate on the property.
- i. A containment area for trashcans must be constructed to minimize the occurrence of wind, animals, or other uncontrollable sources spreading trash to surrounding areas.
- j. Applicant will control weeds and pests (including, but not limited to, gophers) on the parcel for which the permit is granted.
- k. This conditional use permit will expire twenty-four (24) months from the date the written decision is signed if substantial progress toward development of the use permitted by the conditional use permit has not been accomplished or an extension of the life of the permit has been requested prior to the expiration of the permit.

ATTACHMENT A

FIRE APPARATUS ACCESS ROADS

SECTION D101 GENERAL

D101.1 Scope. Fire apparatus access roads shall be in accordance with this appendix and all other applicable requirements of the *International Fire Code*.

SECTION D102 REQUIRED ACCESS

D102.1 Access and loading. Facilities, buildings or portions of buildings hereafter constructed shall be accessible to fire department apparatus by way of an *approved* fire apparatus access road with an asphalt, concrete or other *approved* driving surface capable of supporting the imposed load of fire apparatus weighing at least 75,000 pounds (34 050 kg).

SECTION D103 MINIMUM SPECIFICATIONS

D103.1 Access road width with a hydrant. Where a fire hydrant is located on a fire apparatus access road, the minimum road width shall be 26 feet (7925 mm), exclusive of shoulders (see Figure D103.1).

D103.2 Grade. Fire apparatus access roads shall not exceed 10 percent in grade.

Exception: Grades steeper than 10 percent as *approved* by the fire chief.

D103.3 Turning radius. The minimum turning radius shall be determined by the *fire code official*.

D103.4 Dead ends. Dead-end fire apparatus access roads in excess of 150 feet (45 720 mm) shall be provided with width and turnaround provisions in accordance with Table D103.4.

**TABLE D103.4
REQUIREMENTS FOR DEAD-END
FIRE APPARATUS ACCESS ROADS**

LENGTH (feet)	WIDTH (feet)	TURNAROUNDS REQUIRED
0-150	20	None required
151-500	20	120-foot Hammerhead, 60-foot "Y" or 96-foot diameter cul-de-sac in accordance with Figure D103.1
501-750	26	120-foot Hammerhead, 60-foot "Y" or 96-foot diameter cul-de-sac in accordance with Figure D103.1
Over 750	Special approval required	

For SI: 1 foot = 304.8 mm.

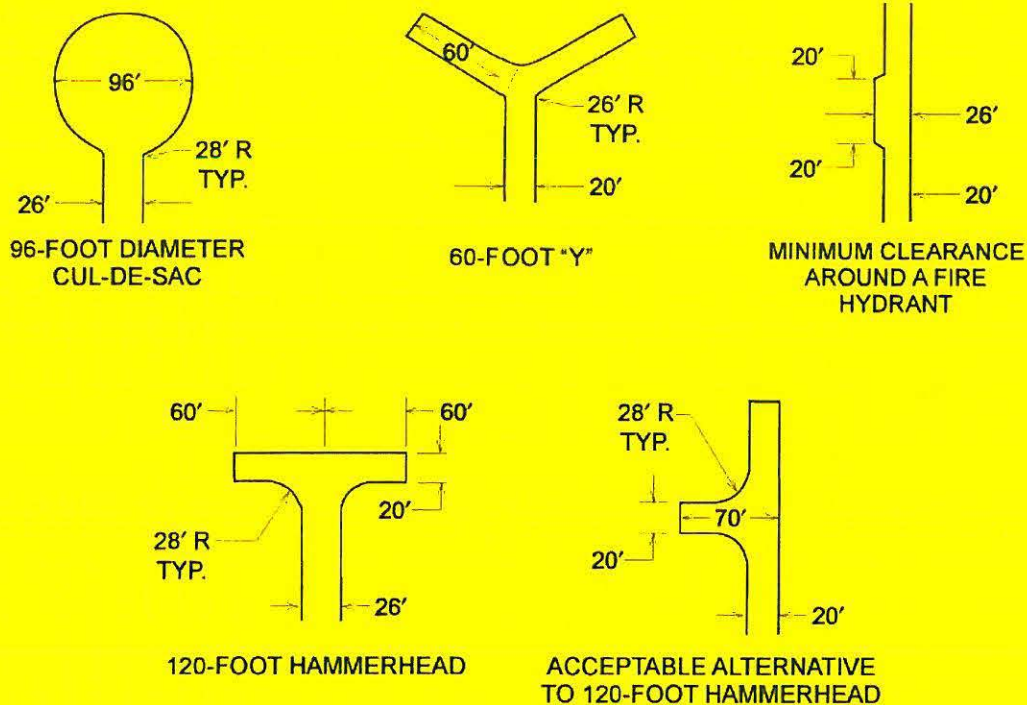

For SI: 1 foot = 304.8 mm.

**FIGURE D103.1
DEAD-END FIRE APPARATUS ACCESS ROAD TURNAROUND**